

### SXG 系列

#### SERIES

基板自立型105°C小型化过电压对应规格设定品  
105°C Miniaturized, Overvoltage Vent Operation Facility, Snap-in Terminal Type

#### ◆ 特 长 / FEATURES

- 105°C、2000小时品。  
Load Life : 105°C 2000 hours.
- 电容器上施加过电压时，对压力阀开启状态进行规格设定的产品。关于详情请咨询我们。  
This series has specification of vent operation in overvoltage situation. Please consult us for any further details.

- 将以往的SXC系列进一步小型化。  
Smaller size than SXC series.
- RoHS指令对应品。  
RoHS compliance.



#### ◆ 规格表 / SPECIFICATIONS

项 目 Items	特 性 Characteristics								
工作温度范围 Category Temperature Range	-25 ~ +105°C								
额定电压范围 Rated Voltage Range	200, 400, 450V.DC								
静电容量允许差 Capacitance Tolerance	±20% (20°C, 120Hz)								
漏 电 流 Leakage Current(MAX)	$I = 3\sqrt{CV}$ (施加额定电压5分钟后) $I = 3\sqrt{CV}$ (After 5 minutes application of rated voltage) I = 漏电流 (µA)      C = 额定静电容量 (µF)      V = 额定电压 (V) Leakage Current      Rated Capacitance      Rated Voltage								
损失角正切值 (tan δ) Dissipation Factor(MAX)	<table border="1"> <tr> <td>额定电压 (V) Rated Voltage</td> <td>200,400</td> <td>450</td> </tr> <tr> <td>tan δ</td> <td>0.15</td> <td>0.20</td> </tr> </table>	额定电压 (V) Rated Voltage	200,400	450	tan δ	0.15	0.20	(20°C, 120Hz)	
额定电压 (V) Rated Voltage	200,400	450							
tan δ	0.15	0.20							
阻 抗 比 Impedance Ratio(MAX)	<table border="1"> <tr> <td>额定电压 (V) Rated Voltage</td> <td>200</td> <td>400,450</td> </tr> <tr> <td>Z(-25°C)/Z(20°C)</td> <td>3</td> <td>8</td> </tr> </table>	额定电压 (V) Rated Voltage	200	400,450	Z(-25°C)/Z(20°C)	3	8	(120Hz)	
额定电压 (V) Rated Voltage	200	400,450							
Z(-25°C)/Z(20°C)	3	8							
耐 久 性 Endurance	在105°C环境中，不超过额定电压的范围内叠加额定纹波电流，连续加载2000小时后，满足以下各项要求。 After applying rated voltage with rated ripple current for 2000 hrs at 105°C, the capacitors shall meet the following requirements.								
	<table border="1"> <tr> <td>静电容量变化率 Capacitance Change</td> <td>初期值的±20%以内 Within ±20% of the initial value.</td> </tr> <tr> <td>损失角正切值 Dissipation Factor</td> <td>规格值的200%以下 Not more than 200% of the specified value.</td> </tr> <tr> <td>漏 电 流 Leakage Current</td> <td>规格值以下 Not more than the specified value.</td> </tr> </table>	静电容量变化率 Capacitance Change	初期值的±20%以内 Within ±20% of the initial value.	损失角正切值 Dissipation Factor	规格值的200%以下 Not more than 200% of the specified value.	漏 电 流 Leakage Current	规格值以下 Not more than the specified value.		
静电容量变化率 Capacitance Change	初期值的±20%以内 Within ±20% of the initial value.								
损失角正切值 Dissipation Factor	规格值的200%以下 Not more than 200% of the specified value.								
漏 电 流 Leakage Current	规格值以下 Not more than the specified value.								

#### ◆ 纹波电流修正系数 / MULTIPLIER FOR RIPPLE CURRENT

频率系数 Frequency coefficient

频率 (Hz) Frequency	60(50)	120	500	1k	10k≤
系 数 Coefficient	0.77	1.00	1.17	1.22	1.40

#### ◆ 产品型号体系 / PART NUMBER

□□□	SXG	□□□□□	□	□□□	SN	D×L
额定电压 Rated Voltage	系列名称 Series	额定静电容量 Rated Capacitance	静电容量允许差 Capacitance Tolerance	副记号 Option	端子记号 Terminal Code	铝壳尺寸 Case Size

#### ◆ 副记号 / OPTION

		记号 Code
PET套管，无底板	PET Sleeve without plate	EFC
PVC套管，无底板	PVC Sleeve without plate	OOE
PVC套管，有底板	PVC Sleeve with plate	无 Blank

#### ◆ 尺寸图 / DIMENSIONS

(mm)

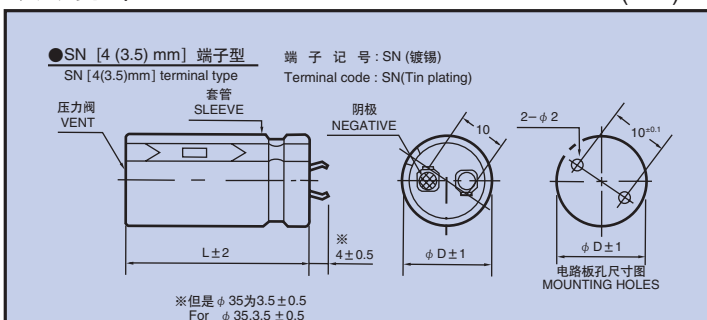

**◆标准品一览表/STANDARD SIZE**

Cap ( $\mu$ F)	WV $\phi$ D	200							
		$\phi$ 20		$\phi$ 22		$\phi$ 25		$\phi$ 30	
150		20×20	0.66						
180		20×25	0.82	22×20	0.80				
220		20×25	0.95	22×25	1.00	25×20	0.87		
270		20×30	1.10	22×25	1.10	25×20	0.95		
330		20×35	1.20	22×30	1.25	25×25	1.20	30×20	1.15
390		20×40	1.31	22×30	1.31	25×25	1.31	30×20	1.25
470				22×35	1.45	25×30	1.45	30×25	1.45
560				22×40	1.60	25×30	1.60	30×25	1.60
680						25×35	1.78	30×30	1.78
820						25×40	1.95	30×35	2.11
1000								30×35	2.40
1200								30×40	2.65

Cap ( $\mu$ F)	WV $\phi$ D	400									
		$\phi$ 20		$\phi$ 22		$\phi$ 25		$\phi$ 30		$\phi$ 35	
39		20×20	0.34								
47		20×20	0.40								
56		20×25	0.45	22×20	0.40						
68		20×25	0.49	22×25	0.52	25×20	0.49				
82		20×30	0.64	22×25	0.64	25×20	0.60				
100		20×35	0.70	22×30	0.70	25×25	0.70	30×20	0.60		
120		20×40	0.75	22×30	0.75	25×25	0.75	30×20	0.70		
150				22×35	0.88	25×30	0.88	30×25	0.85	35×20	0.80
180				22×40	0.95	25×30	0.95	30×25	0.95	35×25	0.95
220						25×35	1.10	30×30	1.10	35×25	1.10
270						25×40	1.22	30×30	1.22	35×25	1.22
330								30×35	1.44	35×30	1.44
390								30×40	1.55	35×35	1.60
470										35×40	1.90

Cap ( $\mu$ F)	WV $\phi$ D	450									
		$\phi$ 22		$\phi$ 25		$\phi$ 30		$\phi$ 35			
47		22×25	0.35								
56		22×25	0.44								
68		22×30	0.53	25×25	0.53						
82		22×35	0.64	25×25	0.64						
100		22×40	0.69	25×30	0.69	30×25	0.69				
120		22×45	0.75	25×35	0.75	30×25	0.75				
150		22×50	0.88	25×40	0.88	30×30	0.88	35×25	0.80		
180				25×45	0.98	30×30	0.98	35×25	0.98		
220				25×50	1.10	30×35	1.10	35×30	1.10		
270						30×40	1.28	35×35	1.28		
330						30×50	1.45	35×40	1.45		
390								35×40	1.60		
470								35×50	1.85		

纹波电流 Ripple Current (A r.m.s./120Hz,105°C)
   
 铝壳尺寸 Case Size  $\phi$  D×L(mm)